



GNSS-303L-A

USER GUIDE

GM-14915163

Rev 2

March 2018

The GNSS-303L-A is an active GNSS antenna that receives the GPS, GLONASS, Galileo, BeiDou, NavIC and L-Band signals.

This guide provides the basic information you need to install and begin using your new antenna.

ADDITIONAL EQUIPMENT REQUIRED

- A device with an antenna input port that both receives the RF signal and provides 3.8 – 6.0 VDC to the antenna is required for the GNSS-303L-A. NovAtel GNSS receivers provide the necessary power through their antenna RF connectors.
- Coaxial cable with a male TNC connector

INSTALLING THE ANTENNA



The integrator of this antenna is responsible for ensuring antenna installation meets all the overall integrated system requirements.



Refer to Section 307 of www.faa.gov/documentLibrary/media/Advisory_Circular/AC%2043.13-2B.pdf for information about antenna bonding in aircraft applications.

Both the input DC power and the output RF signal use a single coaxial cable connected to the unit's TNC female connector.

The antenna attaches to a surface with an ARINC-743 bolt pattern. Four screws pass through the antenna housing.

To install the antenna:

1. Install the supplied o-ring into the groove on the antenna base.



User supplied o-ring grease can hold the o-ring in the groove during installation.

2. Drill the mounting holes and the connector clearance hole on the mounting surface. See the *Mechanical Drawings* section for mounting pattern details.

- Use the four supplied mounting screws to attach the antenna to the mounting surface. The o-ring compresses and creates a seal between the surface and the antenna.



NovAtel recommends thread-locker (not included) on the mounting screws.

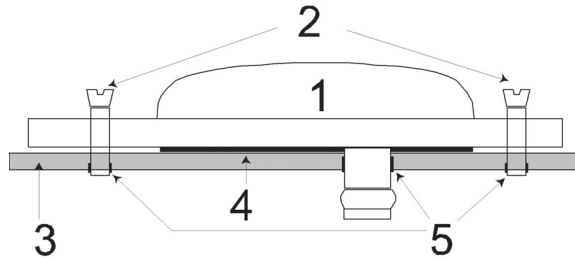

Ref. #	Description
1	Antenna
2	Countersink screws
3	Mounting surface
4	O-ring
5	Drilled mounting holes

- Remove the dust cap from the antenna's TNC connector.
- Attach the coaxial cable's male TNC connector to the antenna's TNC connector.

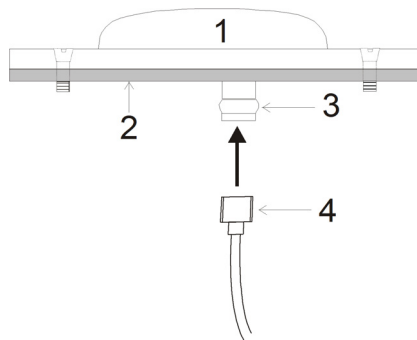

Ref.#	Description
1	Mounted antenna
2	Mounting surface
3	TNC connector
4	Coaxial cable

6. Attach the other end of the coaxial cable to the antenna input port on the receiving device. The receiving device must be equipped to provide power as detailed in the *SPECIFICATIONS* section of this guide. All NovAtel GNSS receivers provide the necessary power through the antenna RF connectors.

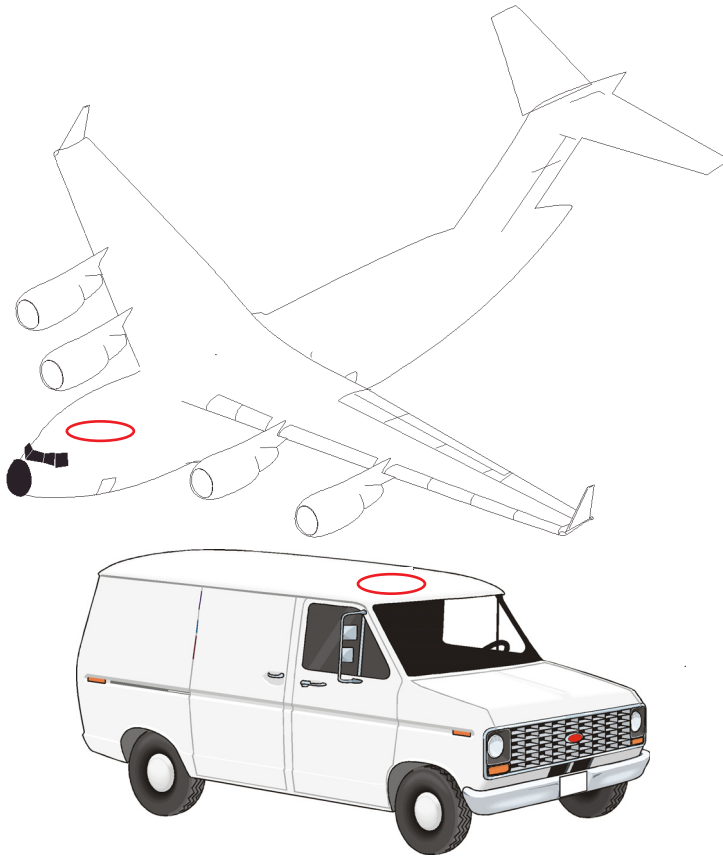

This illustration provides examples of where the antenna may be located on an aircraft or vehicle (not to scale).

ANTENNA CARE

The GNSS-303L-A is designed to withstand the elements, including rain, snow and dust. However, to ensure that the antenna performs optimally, keep the radome clean and brush off any ice or snow. In addition, ensure the TNC connector remains clean and dry and replace the dust cap when a cable is not connected.

SPECIFICATIONS

RF

Operational Band (typical)	GPS L5 1176.45 ±12 MHz Galileo E5, E5a E5b 1164.45 - 1219.14 MHz NavIC L5 1176.45 ±15 MHz		GPS L2 1227.60 ±10 MHz BeiDou B2 1207.14 ±12 MHz		GLONASS L2 1237.83 – 1253.63 MHz Galileo E6 1266.75 - 1290.75 MHz BeiDou B3 1268.52 ±10 MHz		L-Band 1525 –1560 MHz Galileo L6 1542.50 ± 5.0 MHz BeiDou B1 1561.098 ±8 MHz		GPS L1 1575.42 ±10.0 MHz Galileo E1, E2 1575.42 ±12.0 MHz NavIC L1 1575.42 ±12 MHz		GLONASS L1 1592.95 – 1610.38 MHz	
Antenna Gain (dBic) G.P. = Ground Plane	Free Space	4 foot G.P.	Free Space	4 foot G.P.	Free Space	4 foot G.P.	Free Space	4 foot G.P.	Free Space	4 foot G.P.	Free Space	4 foot G.P.
90° zenith	+2.4	+3.0	+2.9	+3.9	+2.4	+3.5	-1.4	-3.2	+4.5	+3.9	+2.0	-3.1
10° elevation	-3.9	-5.1	-3.8	-4.6	-4.4	-5.6	-8.5	-8.7	-2.3	-1.9	-8.8	-8.2
20° elevation	-2.8	-1.8	-2.4	-1.2	-3.0	-1.9	-7.0	-5.4	-1.0	+1.1	-7.5	-5.2
30° elevation	-1.4	+0.3	-0.7	+1.0	-1.5	+0.2	-6.0	-3.9	+0.1	+2.2	-6.4	-4.3
60°-90° elevation	>1.3	>0.5	>1.8	>1.1	>1.1	>0.2	>-2.6	>-5.8	>3.2	>0.7	>-3.1	>-6.3
Beamwidth (3dB)	115°	127°	121°	125°	116°	128°	102°	130°	105°	135°	95°	132°
LNA gain (typical)	30 dB		30 dB		30 dB		26 dB		26 dB		26 dB	
Polarization	Right-hand circular											
Noise figure (typical)	3 dB											
Nominal impedance	50 Ω											
VSWR	< 2.0 : 1											

POWER

Input voltage	3.8 – 6.0 VDC
Current (typical)	< 60 mA

PHYSICAL

Size	Width: 76.20 mm (3.00 in.), Length: 119.38 mm (4.700 in.), Height 26.10 mm (1.028 in.)
Weight	272 g (9.60 oz.)

ENVIRONMENTAL

Maximum altitude	21336 m (70000 ft.)
Operating temperature	-40°C to +85°C (-40°F to +185°F)
Storage temperature	-65°C to +150°C (-85°F to +302°F)
Vibration	>30 G
Designed to meet these standards	DO-160D, MIL-C-5541, MIL-E-5400, MIL-I-45208A and MIL-STD-810

MECHANICAL DRAWINGS

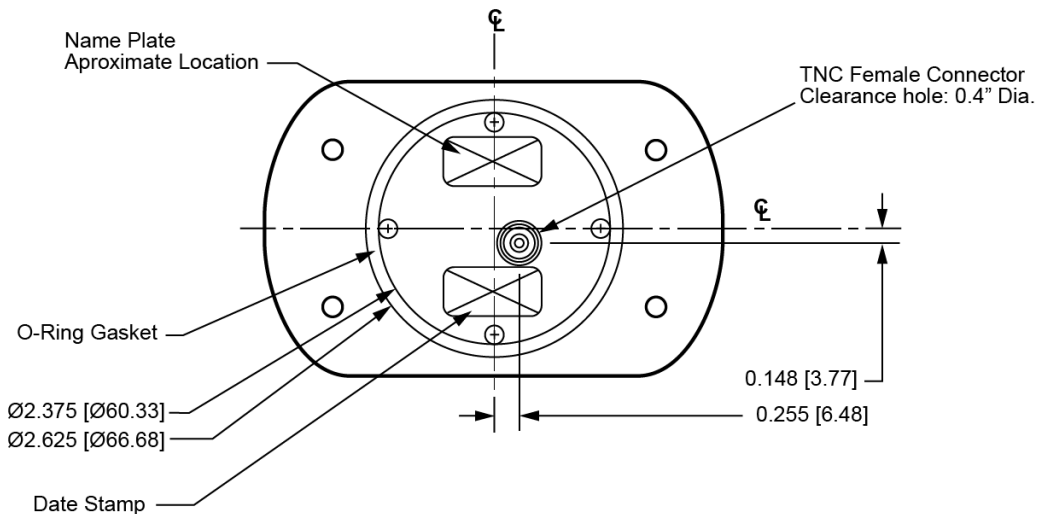
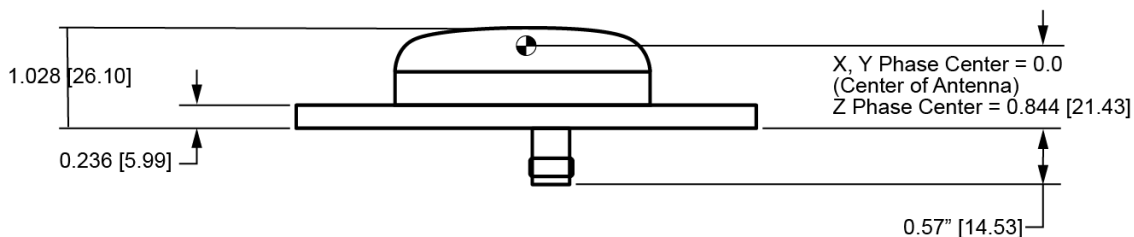
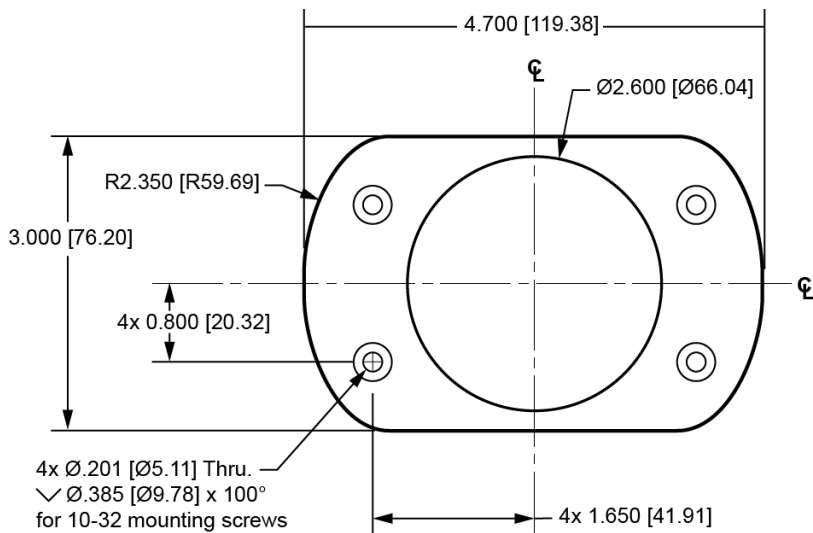

Dimensions are in inches, followed by [mm]

PHASE CENTER

Please refer to the *Mechanical Drawings* before reading this section.

HEIGHT = Vertical phase centre offset from antenna reference point or antenna reference plane (ARP), see the *MECHANICAL DRAWINGS* section of this guide.

For relative offset numbers and phase centre variation (PCV) tables, please visit the U.S. National Geodetic Survey (NGS) website at www.ngs.noaa.gov/ANTCAL/. Look for ANTCOM ACC42G1215A_XT1.

Please check our website for updates to this manual at www.novatel.com/Downloads/docupdates.html and the websites mentioned above.

If you need any further advice on this matter, please visit our website at www.novatel.com. Other methods of contacting Customer Service can be found on the last panel of this guide.

WEEE

If you purchased a GNSS-303L-A antenna in Europe, return it to your dealer or supplier at the end of its life. The objectives of the European Community's environment policy are, in particular, to preserve, protect and improve the quality of the environment, protect human health and utilise natural resources prudently and rationally. Sustainable development advocates the reduction of wasteful consumption of natural resources and the prevention of pollution. Waste electrical and electronic equipment (WEEE) is a regulated area. Where the generation of waste cannot be avoided, it should be reused or recovered for its material or energy. WEEE products may be recognized by their wheeled bin label () .

See www.novatel.com/products/compliance/environmental-compliance/ for more information.

ROHS

The GNSS-303L-A is compliant with the European Union (EU) Restriction of Hazardous Substances (RoHS) Directive 2011/65/EU.

WARRANTY POLICY

NovAtel Inc. warrants that its Global Navigation Satellite System (GNSS) products are free from defects in materials and workmanship, subject to the conditions set forth on our web site: www.novatel.com/products/warranty.

GNSS Antenna™ Modules:	One (1) Year
Cables and Accessories:	Ninety (90) Days

RETURN INSTRUCTIONS

To return products, refer to the instructions found under the Return Policy Tab on the warranty page: www.novatel.com/products/warranty.

QUESTIONS OR COMMENTS

If you have any questions or comments, please log a support request with NovAtel Customer Support using one of the following methods:

Log a Case and Search Knowledge:

Website: www.novatel.com/support

Log a Case, Search Knowledge and View Your Case History: (login access required)

Web Portal: <https://novatelsupport.force.com/community/login>

E-mail:

support@novatel.com

Telephone:

U.S. and Canada: 1-800-NOVATEL (1-800-668-2835)

International: +1-403-295-4900



© Copyright 2018 NovAtel Inc. All rights reserved.
Unpublished rights reserved under international copyright laws.